

FOOT SWITCH SERIES KFS – 227

SPECIAL FEATURES

- Double break contacts with high quality silver alloy tips, having arc – retarding and anti welding properties.
- Provided with specially treated oil resistant rubber gasket to make the switch completely dust proof.
- Ease of maintenance.
- Reliability of performance.
- Resists extreme shocks & vibratory conditions.

Protection	: IP-55
Terminals	: Suitable for conductor size 2.5mm ²
Contact sequence	: 1NO + 1NC (Snap Action)
Rated duty	: 2500 operations per hour
Electrical & mechanical life	: 10 million operations.
Rated insulation voltage	: 500V AC/ DC
Rated thermal current	: 10A

APPLICATIONS

KAKKU Foot Limit Switches Series KFS – 227 are used to provide electrical On/ Off signals for the control circuits of various types of machines like Cranes, Transfer cars, various types of machine tools, stitching & winding machines etc.

TECHNICAL DATA

Ambient temperature	: -10 to +60°C
Mounting	: Surface
Housing	: Cast Aluminium housing with detachable steel cover.

SELECTION CHART

Type	Description
KFS – 227A	Without Guard
KFS – 227B	With Guard

OPTIONAL EXTRAS

- Enclosure upto IP-65
- Suitable base plate to match any mounting dimensions (Furnish drg.)

SERIES KFS – 227
Dimensions (mm)

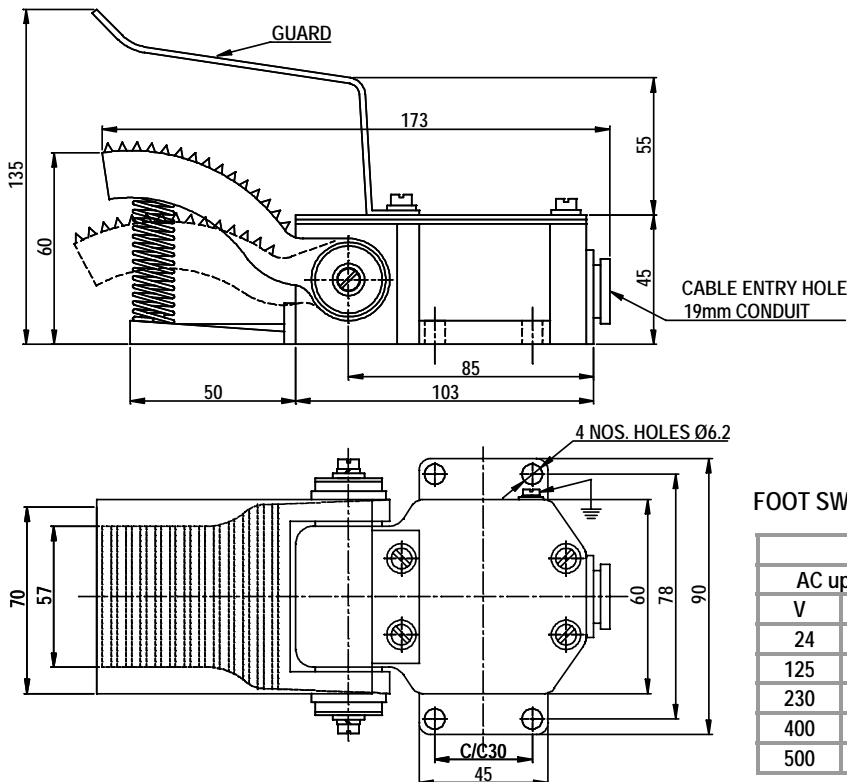

FOOT SWITCH

RATED OPERATIONAL CURRENT					
AC upto 40 to 60 Hz			DC		
V	AC-12	AC-15	V	DC-12	DC-13
24	10	10	24	10	10
125	10	10	48	6	4
230	10	6	110	4	1
400	10	4	220	1	0.4
500	10	3	440	0.5	0.2

Product improvement is a continuous process at KAKKU. Hence data given in this catalogue is subject to revision without notice.

Electronic & Power Control Co.

(AN ENTERPRISE OF KAKKU E & P CONTROL (P) LTD.)

1, Industrial Estate, Bhilai 490 026,
(Chhattisgarh) INDIA.



Symbol Of Reliability

Tel : 91-788-2382610, 2382297
Fax : 91-788-2381797, 2321836
E-mail : kakku_bhilai@yahoo.com