

KAKKU JOY STICK CONTROLLERS (CROSS CONTROL SWITCH) SERIES KCCS

SPECIAL FEATURES

- Available in single as well as dual axis.
- Double break contacts with high quality silver cadmium oxide contact tips having arc-retarding & anti-welding properties.
- Compact & still heavy duty
- Long life with reliable performance and trouble free operation.

APPLICATION

KAKKU Joystick Controllers Series KCCS are used for control of electric drives of hoists, transfer cars, unloaders, controlling of roller tables & stand position at various mill applications, most widely used In control desks & operators interface for motion control , etc

SELECTION CHART

Type	NO. OF 1NO+1NC CONTACT BLOCKS	OPERATION
KCCS-01	2	2-WAY, STAYPUT
KCCS-02	4	4-WAY, STAYPUT
KCCS-03	2	2-WAY, SPRING RETURN
KCCS-04	4	4- WAY, SPRING RETURN

- For dead man contact add suffix "D" to the above types.

TECHNICAL DATA

Ambient Temperature	: 55°C.
Mounting Arrangement	: Panel & control desk mounting
Terminals	: Suitable for conductor size 0.75-2.5mm ² .
Operation	: Stayput / Spring return
Max. No. of operating positions.	: Upto 1-0-1
Contact at each position	: 1NO+1NC, Snap acting.

RATINGS

Continuous Current	: 15A
Rated Voltage	: 500 V Ac or 220 V DC

OPTIONAL EXTRAS

- Enclosure as per IP -54 / 65
- Dead man handle with contact

ORDERING INFORMATION

- Give KAKKU type.
- Name plate details of operation i.e. 'HOIST - LOWER', 'FORWARD - REVERSE' etc.
- Specify optional extras if any.

SERIES MSC-5000
Dimensions (mm)

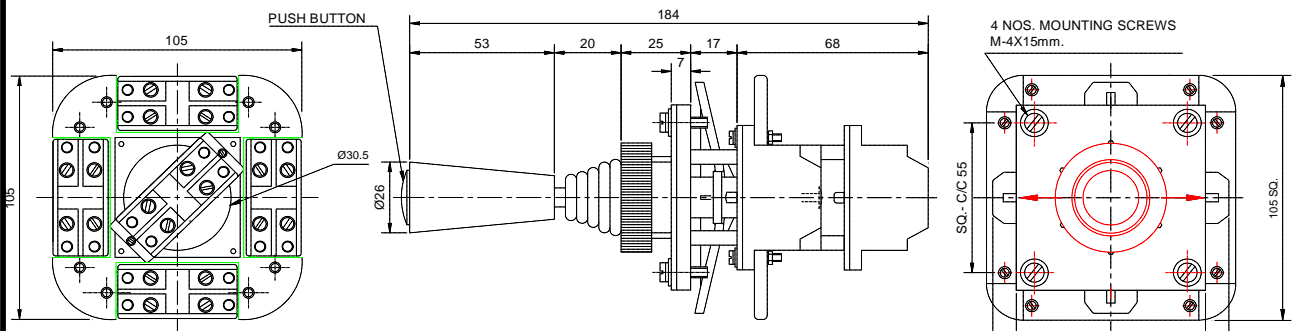

Product improvement is a continuous process at KAKKU. Hence data given in this catalogue is subject to revision without notice.

Electronic & Power Control Co.

(AN ENTERPRISE OF KAKKU E & P CONTROL (P) LTD.)

1, Industrial Estate, Bhilai 490 026,
(Chhattisgarh) INDIA.



Symbol Of Reliability

Tel : 91-788-2382610, 2382297

Fax : 91-788-2381797, 2321836

E-mail : kakku_bhilai@yahoo.com

Website : www.kakkuindia.com

This document was created with Win2PDF available at <http://www.win2pdf.com>.
The unregistered version of Win2PDF is for evaluation or non-commercial use only.
This page will not be added after purchasing Win2PDF.